



The SR series on line double conversion UPS with full time Digital Signal Processor control technology is the perfect solution for mission critical users who demand high reliability, availability and performance from a UPS. The rack/Tower convertible design, input power factor correction, and high efficiency provide a superior level of power quality for sensitive electronic equipment and computers loads.

PRINCIPLES OF WORKING

The backup series is composed by: Rectifier, Inverter, Static Switch, manual by-pass and Battery.

The Rectifier-Inverter line normally feeds the users, and the Battery is kept charged by the Rectifier.

If a black out occurs, the Battery supplies power energy to users always through the Inverter. When the blackout is over, the Rectifier provides for Battery charge.

If a short circuit or an overload occurs to the users, the Static By-pass switches the load over the emergency line. When the fault is over, the Inverter feeds users.

FEATURES

- Rack/Tower convertible design
- Double conversion ONLINE technology
- Full time Digital Signal Processor Control
- Filtered, and stabilized sine wave supply
- High input power factor and low current THD
- Wide input voltage and frequency range, minimizing the battery usage
- Zero transfer time
- Add matching battery cabinets and extend the backup time up to several hours. Superior overload capability
- Battery test, manual and automatic
- LCD display provides real time status and parameter readings
- Advanced Battery Discharge Management to prevent the deep discharge of the batteries during a power failure
- ON LINE – OFF LINE mode settable
- RS232 and USB standard, dry contact, RS485 & SNMP as option
- Emergency Power Off



CONTROL PANEL

The front display panel provides all major systems parameters and operational status of the UPS that include full diagnostics for simple, easy servicing. The SR LCD series UPS with DSP control, systematically checks each component and displays the result using on LCD display. This feature allows service technicians the

ability to pinpoint and repair the UPS very quickly.

- | | |
|--------------------|----------------------------|
| ■ LED indicators: | ■ Control Keypads: |
| 1 Mains_1 LED | 6 ON (& Alarm Silence) Key |
| 2 Mains_2 LED | 7 OFF Key |
| 3 Redundancy LED | 8 Function Key |
| 4 ECO Mode LED | 9 Scroll Keys |
| 5 Common Alarm LED | 10 Enter Key |

■ LCD Display Explanations:

- ✓ Status
Line Mode, Back up Mode, ECO Mode, Bypass Supply, Battery Low Voltage, Battery Bad/Disconnect, Overload, Transferring with Interruption & UPS fault.
- ✓ Parameters
AC Voltage, Frequency, Load Percentage, Battery Voltage & Temperature

INTERFACES

In additional to the standard RS232 with software, the SPH Series UPS also provides 2 additional customer options communication slots.

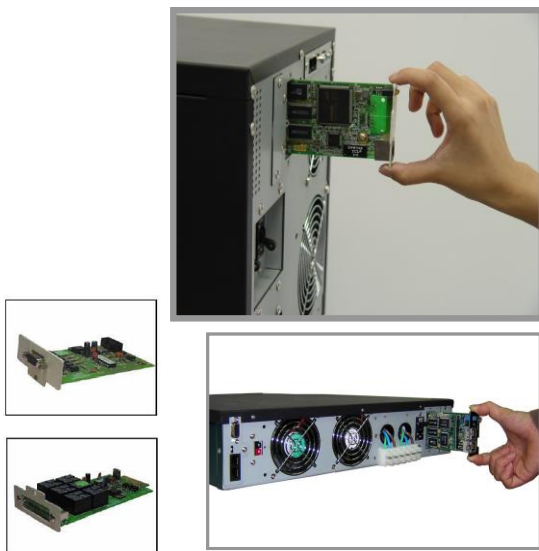

Standard serial RS 232

The smart port is an intelligent RS232 serial port that allows the UPS to a computer. The connector is a standard D-Type, 9 pin, female. The software optionally allows the computer to monitor the mains voltage and the UPS status continuously.

Dry contact card provides isolated contacts for industrial and remote alarm application.

2nd RS232, RS485 and USB port for remote signaling and automatic computer shutdown.

SNMP card for monitoring and integration in network management. The Simple Network Management Protocol (SNMP) is a worldwide-standardized communication-protocol. It is used to monitor any device in the network via simple control language.

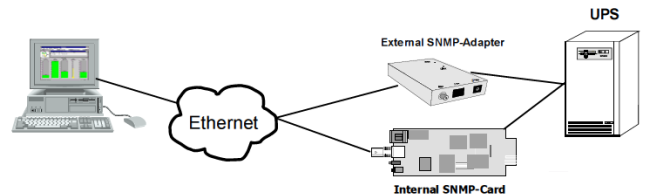

The **Emergency Power Off** facility must use a normally NO contact, which closes to operate the emergency stop procedure. The emergency stop port is located at the rear of the UPS SPH module. Through the dry contact interface it is available also a NC contact.

The SR series UPS is provided with monitoring and shutdown software. The monitoring software provides real-time UPS status display via easy-to-read Meter and Gauges, Digital Table, Block Diagram and Graph Chart as well as remote monitoring of the UPS through Intranet or Internet.

The software is compatible with many operating systems such as Windows 98, 2000, XP, Vista and Windows 7 For other applications like Novell, NetWare, Unix, Linux, please contact your local distributor for a proper solution.

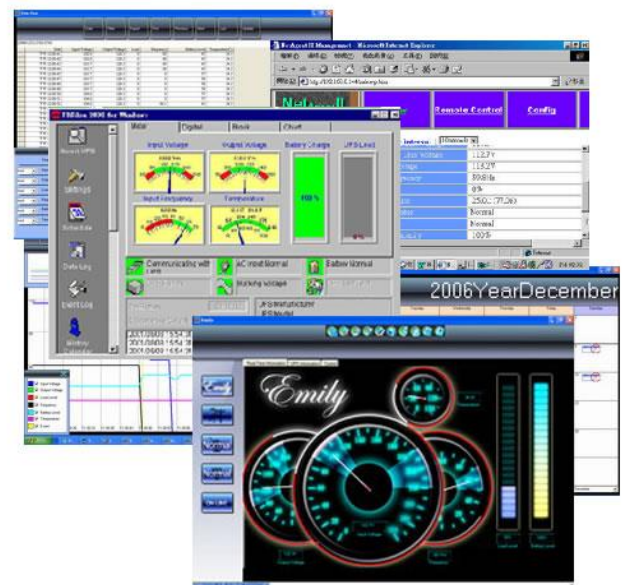

ACCESSORIES

- Additional battery cabinets to upgrade the backup time till several hours even after the first installation. On request the add battery cabinet can be provided with an external independent battery charger to guarantee a fast recharge.

the external maintenance bypass and power output distribution switch allows you to manually transfer the connected equipment to utility power via a maintenance bypass switch and vice versa. It is available till 400 A and it is suitable for single UPS and for a system composed till no. 4 UPS in parallel.

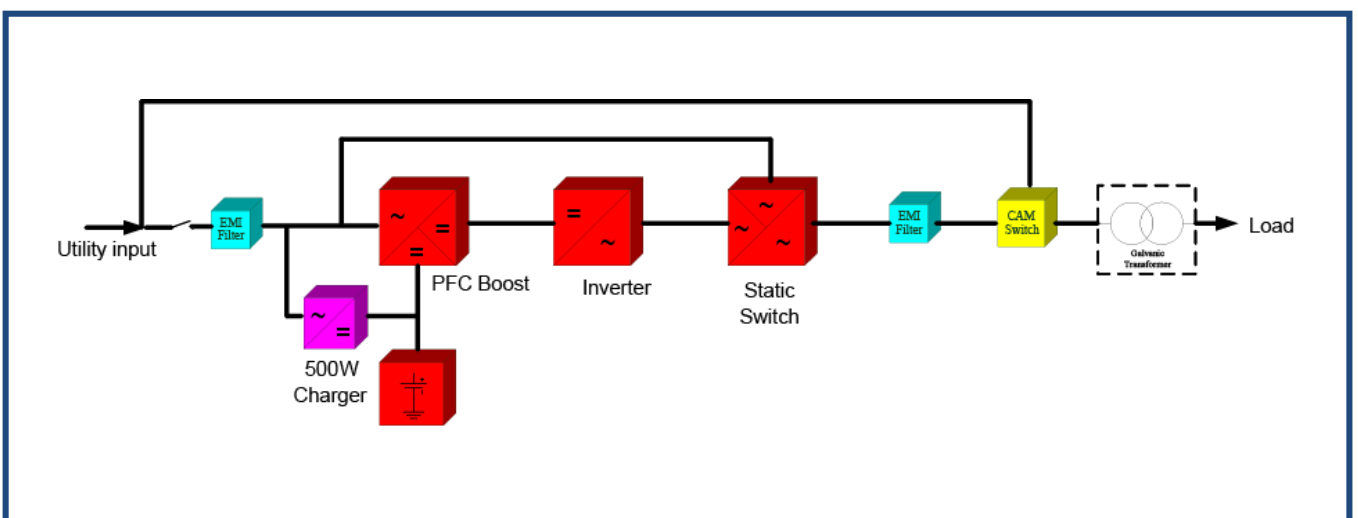

- External Bypass Switch Box Series. Beyond to the standard manual by-pass fitted in each UPS,

Model	SR1000LCD	SR2000LCD	SR3000LCD
Rated power VA/W	1000VA/800W	2000VA/1600W	3000VA/2400W
INPUT			
Nominal Voltage	230V ± 25% 2w		
Frequency window	45 ÷ 66Hz		
Power factor	> 0.99		
Distortione (THiD)	< 6%		
OUTPUT			
Voltage	220/230/240V ± 1% 2w, settable		
Frequency	50Hz or 60Hz ± 0.1%		
Waveform	Sinusoidal		
Distortion (THD)	< 3%		
Transfer time	0 ms.		
Crest factor	3 : 1		
Overload	150% for 1'		
BATTERY			
Type	Maintenance free VRLA		
Recharge time	4h at 90%		
Nominal voltage	36Vdc	72Vdc	72Vdc
Charging current	1.8 A	2.1 A	2.7 A
PROTECTIONS			
Short circuit	Hold whole system		
Over temperature	Switch to by-pass		
Noise suppression	According to EN62040-2		
Spike suppression	According to EN61000-4-5		
MISCELLANEOUS			
Relative humidity	< 90% without condensing		
Operating temperature	from 0°C to + 40°C		
Noise at 1 meter	< 50 dBA		
Interfaces	RS232 and USB (dry contact, RS485 and SNMP as option)		
EPO	UPS shuts down immediately		
Heat dissipation	<145W	<290W	<330W
Output terminals	6 x IEC320-C13		4 x IEC320-C13 1 x IEC320-C19
External battery cabinet	Plug-in & Play		
Dimensions (mm)	440x405x88	440x420x176	440x420x176
Weight (kgs)	15	26	27
STANDARDS			
Safety	EN 62040-1-1, UL1778		
EMC	EN 62040-2, EN 61000-3-2, EN 61000-3-3, FCC classe A		
Marks	CE, cUL, UL		

ELIT Srl reserves his right to do modifications to his products without notice.